

PM8310 TEMUX 336

High Density T1/E1 Framer, VT/TU Mapper & M13 Mux with Integrated SONET/SDH Framers

Preliminary
Product Brief

PRODUCT OVERVIEW

The PM8310 TEMUX 336 is a high density T1/E1, DS3/E3 framer, VT/TU mapper, and M13 multiplexer with integrated SONET/SDH framers for OC-12/STM-4 and 4xOC-3/STM-1 applications. Feature integration and scalability make the TEMUX 336 ideal for use in ATCA/AMC line cards, voice and media gateways, routers, and multi-service and edge aggregation switches.

The TEMUX 336 device's unique Extended Serial SONET/SDH Interface (ESSI) enables:

- A low pin-count interconnect to additional TEMUX 336 devices for equipment protection applications
- Higher-rate SONET/SDH framers such as the PM5336 ARROW 2488 for channelized OC-48/STM-16 designs
- SONET/SDH cross-connects in transport applications
- Ethernet over SONET/SDH mappers such as the PM4390 ARROW M8xFE

Additionally, the device's Scalable Bandwidth Interconnect (SBI) bus enables a simple interconnect to PMC-Sierra Layer 2 solutions such as the FREEDM (HDLC processor), S/UNI IMA (ATM inverse multiplexer) and AAL1gator (ATM-based CES processor) families.

BENEFITS

- Complete SONET/SDH front end with T1/E1, DS3/E3 framers/mappers/ multiplexers on a single chip that meets ATCA/AMC space and power constraints
- Integrated SBI bus simplifies interconnection to layer 2 processors

- Meets timing requirements for wireless backhaul, critical for CES-based PWE3 applications, by enabling independent timing for all 336/252 T1/E1s across the SBI using the V4 byte
- Extended Serial SONET/SDH Interface (ESSI) can aggregate up to 4x OC-3/STM-1 on a single 4-wire interface, enabling equipment protection in ACTA/AMC systems
- Supports linear 1+1 protection on the same device or to a companion TEMUX 336 device
- Enables a scalable architecture from T1/E1 up to OC-12/STM-4
- Supports T1/E1 mapping directly into SONET/SDH using VT1.5/TU-11 or VT2/TU-12 or multiplexed in DS3s using M13 or G.747
- Supports advanced test features including programmable pattern generation and detection for up to 64 byte sequences
- Fully integrated, monolithic IC ensures reliability

PRODUCT HIGHLIGHTS

- 8 OC-3/STM-1 or 2 OC-12/STM-4 SONET/SDH framers
- 336 T1/252 E1 framers
- 12 M13 multiplexers, including support for G.747 multiplexing
- 12 DS3/E3 framers
- High order path processor for a SONET STS-12 or an SDH STM-4
- Tributary path processor for 336 VT1.5/TU-11s or 252 VT2/TU-12s
- Byte-synchronous and bit-asynchronous mapper for 336 VT1.5/TU-11s or 252 VT2/TU-12s
- Tributary path processor for 12 TU-3s
- Mapper for 12 DS3s or 12 E3s (TU-3 and AU-3)

BLOCK DIAGRAM

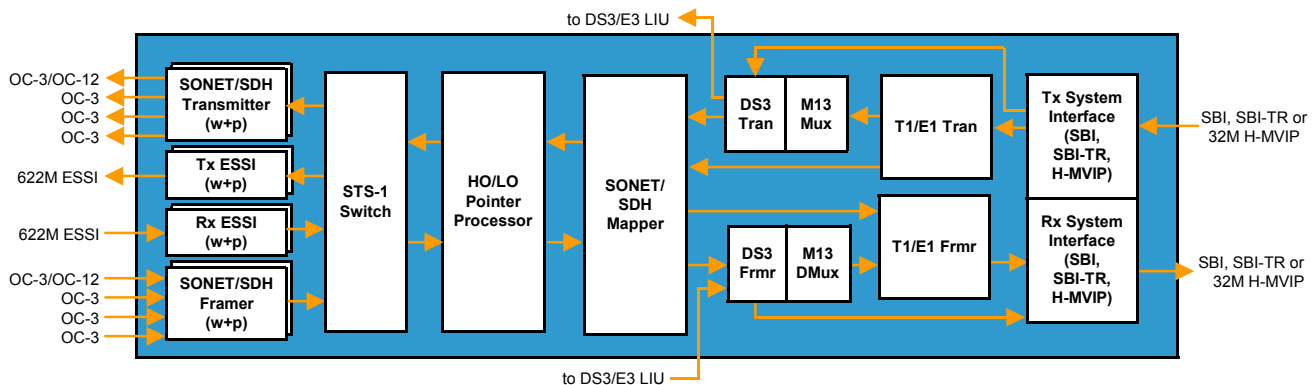

INTERFACES

- Up to 8 SONET/SDH Network interfaces; 2 may operate at OC-12/STM-4 rates
- SONET/SDH Transport and Path overhead interfaces
- Two 622-Mbit/s Extended Serial SONET/SDH interfaces (ESSIs)
- Line side serial interface for up to 12 DS3s or E3s
- System-side Scalable Bandwidth Interconnect (SBI) bus for high density interconnection of up to 336 T1 streams, 252 E1 streams, 12 DS3 streams, 12 E3 streams, or 12 arbitrary rate streams
- System-side serial interface for up to 12 DS3s or E3s
- Flexible bandwidth interface for up to 12 fractional rate links
- 32 Mbit/s synchronous TDM interface (based on H-MVIP)
- Microprocessor- and IEEE 1149.1-compliant JTAG interface
- 16-bit microprocessor interface
- Supports transparent virtual tributaries (TVT) where VT1.5/TU-11 and VT2/TU-12 payloads are transported intact between the line side and the SBI336 bus with pointer processing and low order path processing; TVT mode is configurable on a per-tributary basis
- Provides optional jitter attenuation on the T1/E1 transmit and receive paths, and DS3/E3 transmit and receive paths including DS3/E3s demapped from SONET/SDH

PACKAGE

- 896-pin FCBGA (31 x 31 mm)
- Supports industrial temperature range (-40 °C to 85 °C)

TRANSPORT EQUIPMENT ADM, MSPP & PACKET ADMs

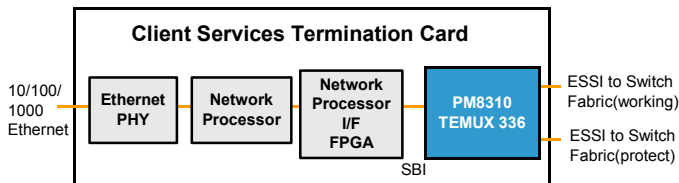

3G BASE STATION/RADIO NETWORK CONTROLLER

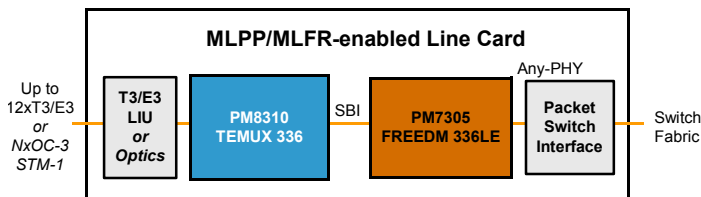

APPLICATIONS

- ATCA/AMC-based line cards
- Voice and media gateways
- Wireless base station controllers (BSC) and radio network controllers (RNC)
- Routers and multi-service switches
- Edge aggregation switches
- Multi-service provisioning platforms

ROUTER/MULTI-SERVICE SWITCH

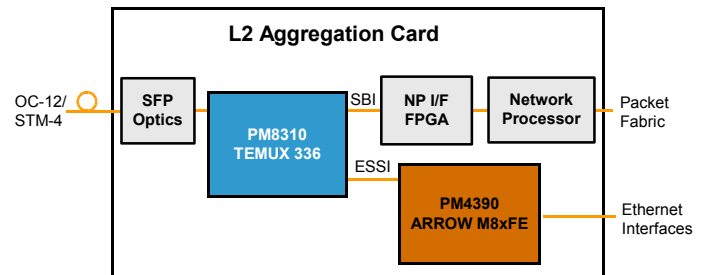

OC-48/STM-16 LINE CARD

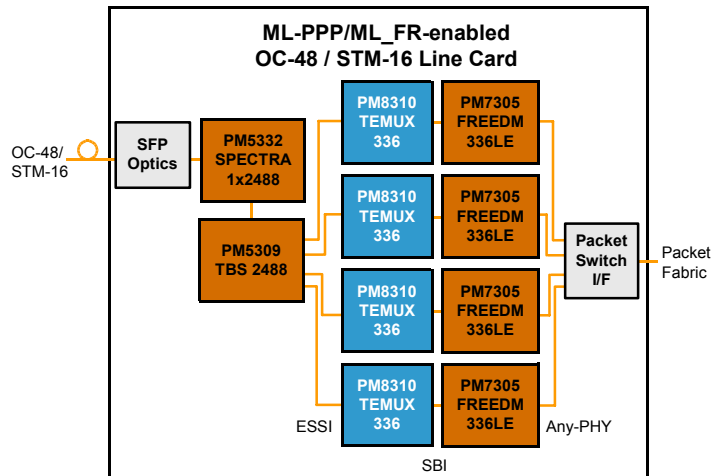

FURTHER RESOURCES

WIRELINE EQUIPMENT SOLUTIONS

www.pmc-sierra.com/ethernet-sonet-sdh-mac-framer-controller-chips

TECHNICAL DOCUMENTATION

www.pmc-sierra.com/products/DocFind.html

Corporate Head Office:
 PMC-Sierra, Inc.
 Mission Towers One
 3975 Freedom Circle
 Santa Clara, CA, 95054, U.S.A.
 Tel: 1.408.239.8000
 Fax: 1.408.492.1157

Operations Head Office:
 PMC-Sierra, Inc.
 100-2700 Production Way
 Burnaby, BC V5A 4X1 Canada
 Tel: 1.604.415.6000
 Fax: 1.604.415.6200

PMC-2060576, Issue 1 © Copyright PMC-Sierra, Inc. 2006. All rights reserved. For a complete list of PMC-Sierra's trademarks, visit www.pmc-sierra.com/legal/. Other product and company names mentioned herein may be the trademarks of their respective owners. For corporate information, send email to: info@pmc-sierra.com. All product documentation is available on our web site at: www.pmc-sierra.com.

